



PACKING

AL AUTOLOAD LINE

Technical Data

Dimensions:	Length:	approx. 10720 mm
	Width:	approx. 1950 mm
	Table level:	approx. 1000 mm
	Overall height:	approx. 1820 mm (with GBK 420, depending on components installed)
Product dimensions:	Length:	400 mm
	Width:	max. 230 mm
	Height:	max. 150 mm
Capacity:	max. 36000 products / h (depending on packing schemes)	
Configuration:	between 4 and 12 products per pack	
Power supply:	230/400 Volt / 50 Hz	
Power input:	7.0 kW (depending on components installed)	
Compressed air:	min. 6.0 bar (ISO 8573-1)	
Controller:	Omron	
Frequency converter:	Hitachi	
Weight:	2900 kg (depending on components installed)	

Available additional equipment:

- › Individual control unit if combined with local packaging machines
- › Band slicer with one or two band blades
- › Disc slicer with max. 5 blades
- › Product ejection system (in case of material jam due to downstream line units)

18 C



GHD Georg Hartmann Maschinenbau GmbH

Schwalbenweg 24
 D-33129 Delbrück, Germany
 Tel: +49 (0) 5250.9843-0
 Fax: +49 (0) 5250.9843-33

Web: www.ghd.net
 E-mail: info@ghd.net



- › AL IK
- › AL ID
- › AL IQ
- › ALL 1
- › ALL 2





AL Autoload Line

The modular machines from GHD Hartmann form a customized autoload line.

Hamburger, hot dogs or other bun-shaped baked goods are taken over in the Autoload line by the Grouping unit GP within parallel lanes and counted and grouped. In this section, the products can be buffered and manually controlled if necessary. Optionally followed by a multiple disc slicer DS for introducing horizontal hinge cuts or butterfly cuts into the products. The Autoload line offers the option of integrating a HB 1 or HB 2 Horizontal Band Slicer HB 1 or HB 2 for full cutting or a vertical disc slicer.

Depending on the products and packaging schemes, different autoload devices can bring together the multi-lane grouped products next to and above each other. This is done customer specific either by an autoload device with curve AL IK, an autoload device at right angles on a plane AL L1 or with an autoload device at right angles on two planes AL L2. These devices stand for an optimal packaging result in direct connection with a GBK packaging machine.

The connection to a flow packaging machine can be done by an autoload device with cross slide AL IQ, or as an autoload device AL ID with slide and integrated product group turning function.

Optimal:
Zentralverstellung für Messer-
positionen in Höhe und Einschnitt-
tiefe.



Optimal:
Sichere Produktführung mit einfacher
Verstellmöglichkeit.

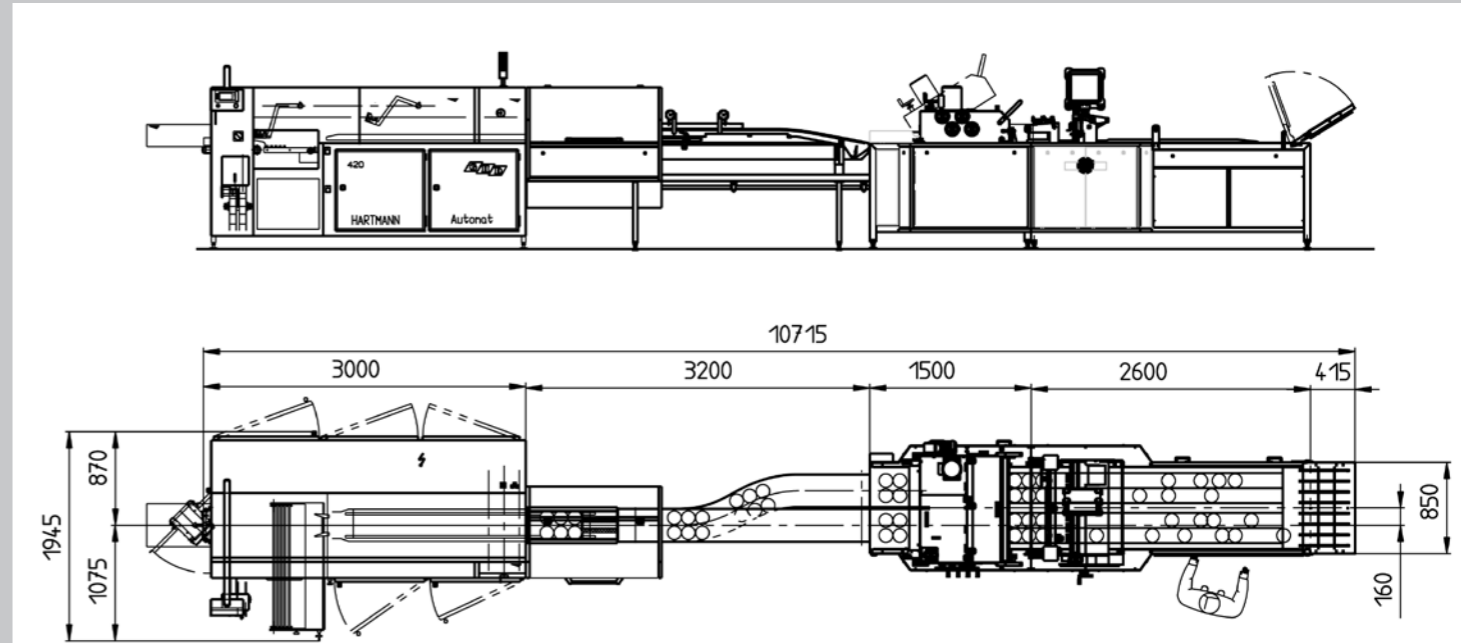

Non-binding suggested set-up drawing.



Overview of Autoload-line features

- › Modular design
- › Grouping of unsorted products
- › Simple, universally refittable infeed system
- › Synchronisation with a Hartmann packaging machine by timing shaft
- › Continuous grouping and feeding procedure
- › In-line supplementary disc slicer and horizontal band slicer



↗ GBK 420 fed by AL 50 Autoload.